

Pilot Biometrics

ECG WAVEFORM CAPTURES

Team Number: 18-12
Client: Rockwell Collins
Adviser: Akhilesh Tyagi

Team Members/Roles
Ryan Gallus – Team Lead
Zach Glanz – Driver Design Lead
Justin Bader – PCB Design Lead
Andrew Jones – Algorithm Design Lead
Kory Gray – Operating Systems Lead
David Kirpes – Circuit Design Lead

Team Email: sdmay18-12@iastate.edu
Team Website: <https://sdmay18-12.sd.ece.iastate.edu/>

Revised: 10/29/2017 – V2

Contents

1 Introduction	2
1.1 Project statement	2
1.2 purpose	2
1.3 Goals.....	2
2 Deliverables	3
3 Design.....	3
3.1 Previous work/literature	3
3.2 Proposed System Block diagram	4
3.3 Assessment of Proposed methods.....	4
3.4 Validation	5
4 Project Requirements/Specifications	6
4.1 functional	6
4.2 Non-functional.....	6
4.3 Standards	6
5 Challenges.....	7
6 Timeline.....	8
6.1 First Semester	8
6.2 Second Semester	8
6.3 Overall project.....	8
7 Conclusions	9
8 References.....	9

1 Introduction

1.1 PROJECT STATEMENT

Pilot Biometrics is a project to develop a device that will capture, monitor, and analyze the ECG waveform of a military pilot in flight, to be used during training operations. The device will use four high-fidelity ECG sensors to collect an accurate waveform, then filter out background noise and interference. Finally, the device will analyze the waveform data to detect if the pilot is in distress, while also storing an encrypted copy of the data and packaging a copy for real-time transmission to the ground through a component in the cockpit. The device will operate on its own power supply and will be capable to running continuously for 4-5 hours.

1.2 PURPOSE

The purpose of this project is to provide critical medical information to decision makers on the ground about the conditions of military pilots in flight during training missions. While in the air, military pilots must be capable of performing harsh maneuvers which induce serious G-forces. These forces can have a significant impact on the health of the pilot, especially when other factors are influencing their health (diet changes, illness, lack of sleep). If a pilot in flight is experiencing a high level of distress, they are at risk of falling unconscious and injuring themselves or other pilots in the air. It is also important for medical officers to be able to evaluate the health of pilots throughout their training. Our project aims to provide this information in real-time.

1.3 GOALS

- Comprehensive project design review
- UNIX installation onto a microcontroller
- Creation of a device driver
- Software filter design for ECG waveform data
- Algorithm design for analyzing ECG waveform data
- Communication protocol for ADC to microcontroller
- Consistent power supply for minimum of 4 hours of continuous operation
- Custom printed circuit board (PCB) design and implementation
- Breakaway ECG sensor harness design
- Proof of reliable detection (no false positives)
- Communication protocol with operator (pilot)
- Communication protocol with ground station

2 Deliverables

- Integrated Schedule with Project Milestones
- Detailed Process Diagram
- Software Filter Algorithm
- ECG Analysis Algorithm
- 4-Layer Printed Circuit Board Integrating ADC and Microcontroller
- Breakaway ECG Sensor Harness
- Integrated Power System

3 Design

3.1 PREVIOUS WORK/LITERATURE

Several methods exist for accurate ECG detection and capture. We have also found significant documentation on how placement of ECG sensors affects waveform fidelity. This will be critical in determining how to capture an accurate waveform without interfering with a pilot's safety harness and ability to eject from an aircraft. Our project will utilize four ECG sensors, two across the chest and two across the lower abdomen to capture a high-fidelity waveform with minimal interference.

Research also exists for determining overall heart stress based on ECG waveform. Our device must be able to detect distress with a high degree of accuracy as false positives are unacceptable. Research suggests heart rate variability and morphologic variability of ECG signal data is an accurate indicator of mental stress. Research also recommends using various machine learning techniques to analyze ECG waveforms for signs of distress. Significant research exists for filtering noise out of waveforms, using both hardware and software designs. Our team will consider both options based on accuracy and speed of execution.

3.2 PROPOSED SYSTEM BLOCK DIAGRAM

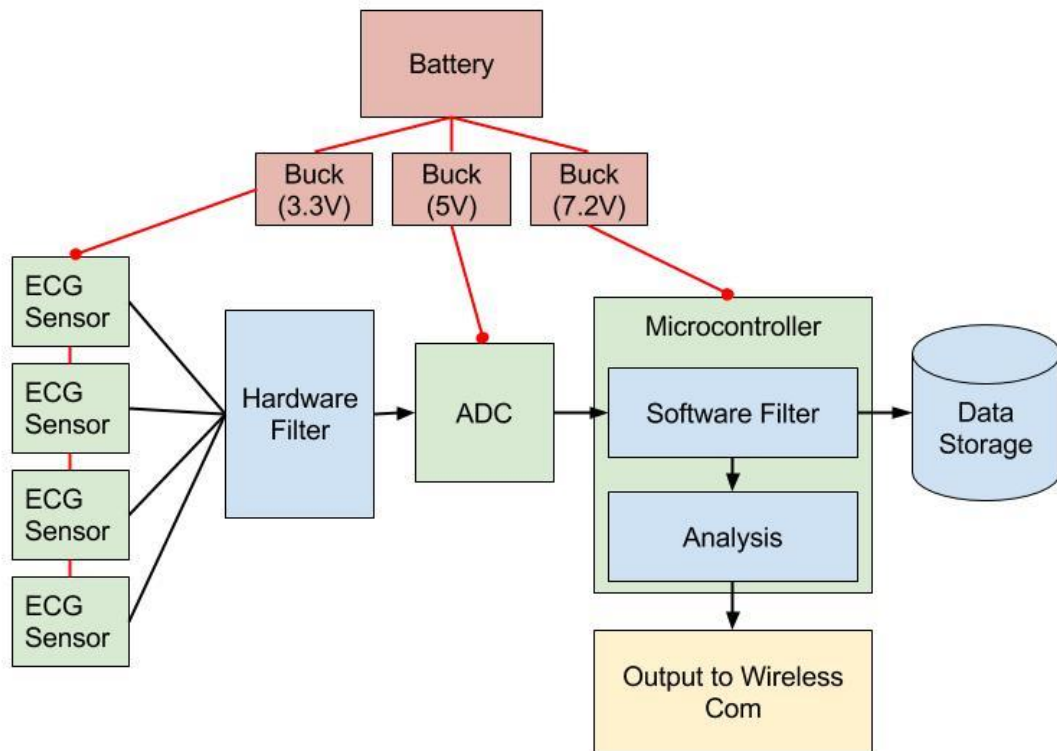

Above is our System Block Diagram, showing all the components of the ECG waveform capture system. Red blocks indicate components of the electrical system, with red wires indicating power transmission. Green blocks indicate main hardware components, which require power. Black lines indicate data transmission. Blue blocks indicate subcomponents of the system, which do not require power. Yellow blocks represent a data output format.

3.3 ASSESSMENT OF PROPOSED METHODS

For capturing an ECG waveform, we have decided on a four-sensor design with two sensors placed on each side of the upper chest, and two on each side of the abdomen. Using four sensors will give us a highly accurate waveform and help reduce noise. Sensor data will then pass through a hardware filter before going into an Analog to Digital Converter (ADC).

To filter out background noise and signals from the ECG sensor, we considered both a hardware filter design and a software filter. We decided to use a combination of high order bandpass hardware filter and an integrated software filter running on the microcontroller. The hardware filter will help eliminate noise outside of the established frequency of the ECG. For the software filter, we will use a k-means clustering data analytics technique to eliminate additional noise and anomalies in the waveform.

To analyze the filtered waveform, an algorithm running on the microcontroller will need to perform several operations. As new data comes in, it will continue to assess whether or not the ECG waveform indicates the pilot is in distress. While analyzing, it will also encrypt and store the filtered ECG waveform, and send formatted data packages to a wireless communication component in the cockpit.

One system requirement is that the device be able to run continuously for a minimum of four hours. We considered both an integrated battery and dedicated power from the cockpit. Because of the minimal power requirements of our hardware, we decided to use a battery. The battery will provide power to four ECG sensors, the ADC, and the microcontroller board.

3.4 VALIDATION

Rigorous validation of our ECG waveform capture system will be required as false positive indications of pilot distress are unacceptable. To ensure a high degree of accuracy, we will break our testing into three categories: component testing, simulations, and live in-flight validation.

Component testing consists of individually activating and measuring results from each piece of the system. The main components we will be testing are the Analog to Digital Converter (ADC), the software and hardware filters, the battery, and the ECG sensors. To test the ADC and filter designs, we will use the arbitrary waveform generator in the lab to create sample data. We will also test with ECG waveform data available online, adding in random noise. To test the battery, we will measure power output through various charge and discharge cycles. For the ECG sensors, we will need to test the outputted waveform through all kinds of noisy conditions, especially high-vibration environments. We will also use the ECG sensors to test the memory requirements needed to store 4-5 hours of encrypted operational data.

After each component has been tested individually, we will begin simulations. Simulation testing will validate the device as a whole, with a user in simulated flight. While operating a flight simulator and wearing the ECG waveform capture device, the user will be asked to perform increasingly difficult tasks while maintaining control of the simulator aircraft. This approach will induce stress that is similar to what a pilot flying a training mission may experience. We will explore a variety of simulated conditions and use several test subjects to ensure the data is generalizable.

Finally, the ECG waveform capture system will be tested in flight by a real pilot at the University of Iowa's Operator Performance Lab (OPL). The lab will give us the opportunity to test the device in real-world conditions, which will give us better insights into what kind of noise and interference we need to account for in our filter. We will also be able to test that the device does not interfere with a pilot's safety and primary tasks. Further feedback from the pilot may also be useful for making operational changes.

4 Project Requirements/Specifications

4.1 FUNCTIONAL

- Accurately detect a pilot in distress
 - Capture ECG waveform of pilot in operation
 - Accurately identify distress based on waveform
- 4-5 hours of continuous operation
 - Consistent and reliable power supply
- Notify pilot or ground station
 - Communicate danger to pilot without increasing distress
 - Communicate with ground teams
- Store 4-5 hours of operational data
- Operate in real time on an ARM microcontroller

4.2 NON-FUNCTIONAL

- Don't interfere with pilot's primary tasks
 - Flight operations
 - Emergency ejection
- Don't interfere with pilot's safety harness
- Don't interfere with pilot's normal communications

4.3 STANDARDS

Our project will abide by military standards for medical record data, as well as ECG waveform capture standards for data storage. Our product will also comply with US export control standards.

One of the standards that we will have to uphold will be keeping the medical data safe. The way that we will be doing this is by encrypting any medical data that is being transferred and stored. We will also be using Health level 7 standards for communicating the current status of the pilot with the ground.

Health Level 7 is a standard for communicating medical information. It defines how a message should be formatted when transmitting medical data. This standard will be used because it is the most accepted standard for medical information transmittal and it will make it easy to allow for other systems to talk to our system if Rockwell Collins decides to add features to our device.

Given the assumption that the military will require all medical data both stored and transmitted to be encrypted we will be using AES encryption to encrypt any data that is being stored or

transmitted. We will be doing this in a modular way as well so that Rockwell Collins can modify our code easily to use the type of encryption that the military uses but is not available to the public.

5 Challenges

Our team has identified several main challenges in the development of our product. The first challenge will be researching and implementing an accurate filter design to eliminate noise. Pilots operate in an environment with a significant amount of vibrations and signal interference, which will make it a challenge to collect an accurate ECG waveform. Our team is also concerned about the possible execution speed limitations of a software filter operating in real time on the microcontroller. If we develop the design and the microcontroller is unable to filter the waveform quickly enough, it will hurt the performance of the device. One possible solution is to use a combination of hardware and software filters to meet performance and accuracy needs.

The second challenge our team identified is in designing the device driver. We want to ensure the final product is highly portable and capable of running on systems with different hardware, which may require a specific driver design. One possible solution will be to research many driver designs, find one that best fits our needs, and base our design on this.

A third challenge we are facing is in meeting rigorous real-time performance needs on the microcontroller. In addition to the software filter, our algorithm will need to analyze the ECG waveform for signs of distress, encrypt and store a full copy of the waveform, and package the data for communication with the ground through a component in the cockpit. To tackle this challenge, we will need to carefully consider performance needs of each part of the algorithm.

One final challenge we identified is how to best test our product once we have a prototype developed. Because our product is meant to be used in flight by a trained pilot, it is very difficult to replicate the necessary conditions on the ground. To tackle this problem, we intend to test the product in a variety of ways and closely simulate the conditions as best as possible.

6 Timeline

6.1 FIRST SEMESTER

week 5	week 6	week 7	week 8	week 9	week 10	week 11	week 12	week 13	week 14
Create Website		Interface ADC with microcontroller				Develop Alorithm to interpret ECG			
Project Plan			Install OS on board						
	Test ADC		Develop device drivers						
				Develop power distribution system					
				Test ECG Sensor					

6.2 SECOND SEMESTER

week 1	week 2	week 3	week 4	week 5	week 6	week 7	week 8	week 9	week 10	week 11	week 12	week 13	week 14
Design Harness			Manufacture Harness				Work on Presentation				Present Design		
Design PCB					Test and Refine Harness								
Test and Modify ECG Algorithm													

6.3 OVERALL PROJECT

Pilot Biometrics Schedule



7 Conclusions

Our project is to create a system which captures ECG waveforms of a pilot in flight to detect situations where they are in serious distress. Our client, Rockwell Collins, has sent us several pieces of hardware, including an ARM M7 microcontroller board and an analog to digital converter (ADC). Our goal is to design a system capable of running continuously for 4-5 hours. The system will use ECG sensors to capture heart stress data, which will go into the ADC and then to our microcontroller. The microcontroller will filter and analyze the data, before storing an encrypted copy and packaging for transmission with the ground.

8 References

Client: JR Spidell at Rockwell Collins

Faculty Advisor: Dr. Akhilesh Tyagi

ECG Waveform Resources:

1. M. Marouf, G. Vukomanovic, L. Saranovac and M. Bozic, "Multi-purpose ECG Telemetry System", Biomedical Engineering Online, 2017. <https://biomedical-engineering-online.biomedcentral.com/articles/10.1186/s12938-017-0371-6>
2. ECG Library, a collection of realistic ECG recordings. <https://ecglibrary.com/ecghome.php>
3. Goldberger AL, Amaral LAN, Glass L, Hausdorff JM, Ivanov PCh, Mark RG, Mietus JE, Moody GB, Peng C-K, Stanley HE. PhysioBank, PhysioToolkit, and PhysioNet: Components of a New Research Resource for Complex Physiologic Signals. *Circulation* 101(23):e215-e220 [Circulation Electronic Pages; <http://circ.ahajournals.org/content/101/23/e215.full>]; 2000 (June 13). <https://physionet.org/physiotools/software-index.shtml>

STM32 MCU Nucleo Microcontroller Resources:

4. STMicroelectronics, NUCLEO-F767ZI Description and technical documents. http://www.st.com/content/st_com/en/products/evaluation-tools/product-evaluation-tools/mcu-eval-tools/stm32-mcu-eval-tools/stm32-mcu-nucleo/nucleo-f767zi.html
5. EMCraft, uClinux BSP provider. <https://emcraft.com/index.php/products/413>